

Compressor Inlet
HOSE CONNECTIONS
TABULATED AS (Ø x L)

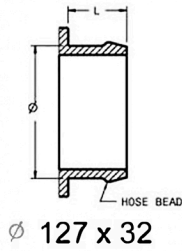

Compressor Outlet

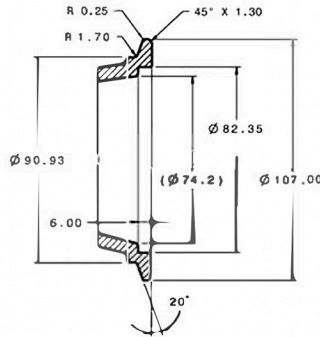

Oil Inlet

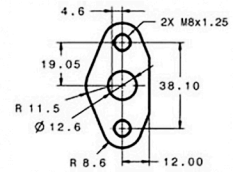

Turbine Inlet

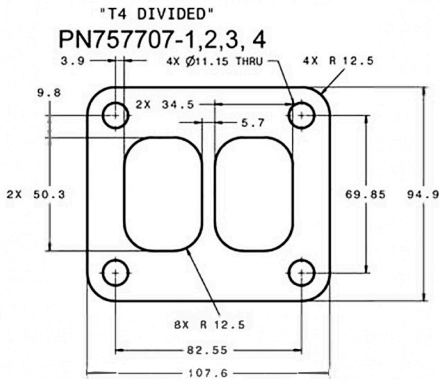

Turbine Outlet

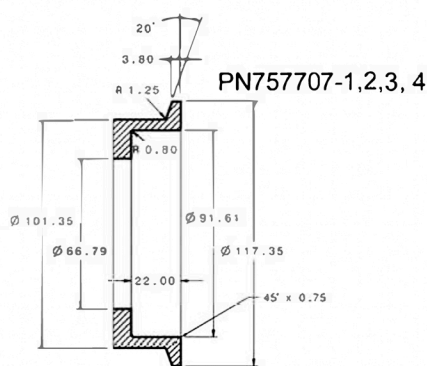

Oil Outlet

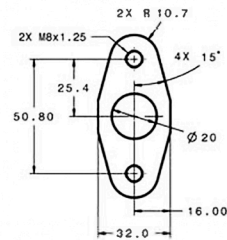

Water

M18 x 1.50

"LARGE FRAME DIESEL DIVIDED"
PN757707-9, 10

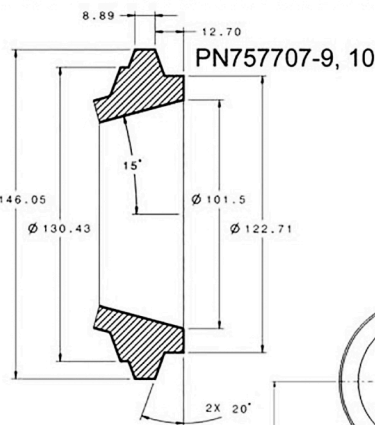
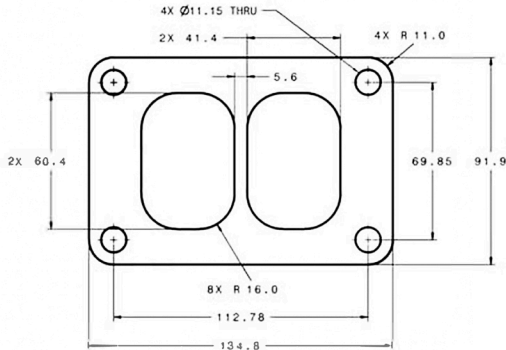

All Measurements in MM

